



X5 Pipeline: X-ray Inspection System

Designed for Food & Packaging Industries

Product Highlights

- X-ray system designed for use in pipelines with a wide range of free flowing product (processed meat, poultry, sauces, jams, slurries, etc.)
- Excellent detection of all metals, bone, glass and dense plastics
- 2.5" or 3" pipe diameter cassette, with ARU (2.5") and ARL (2.5 or 3") reject options.
- Compact foot print, requiring 400 mm pipe length (without Reject or S-bends)
- Suitable for integration with Handtmann, Vemag or Risco Fillers
- Built for 24/7 operation with pass key Protective Set-up for added security and control
- Windows 10 Industrial Grade PC with Ethernet and USB Port

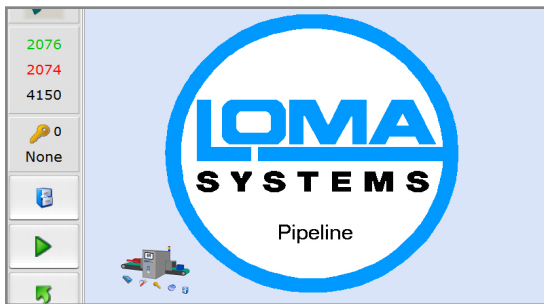

Easy to Use Intuitive Full Color Touchscreen

The X5 Pipeline includes an Icon driven full colour touchscreen control interface with easy to use product learn and features and layout.



Excellent Metal Detection Levels and also Bone, Stone, Glass and Dense Plastic

The X5 Pipeline provides offers great inspection capabilities on Bone as well as stainless steel, ceramic, glass and dense plastics.



Removable cassette for easy cleaning

The cassette is designed to make cleaning easy and provide a simple option when changing between different size pipes.



Note: S bends are an optional extra with this system



Environment Ready, IP69k Independently Rated

Fully IP69k rated and designed for harsh high-temperature, high-pressure wash-down environments with easy to clean components.

Technical Specification

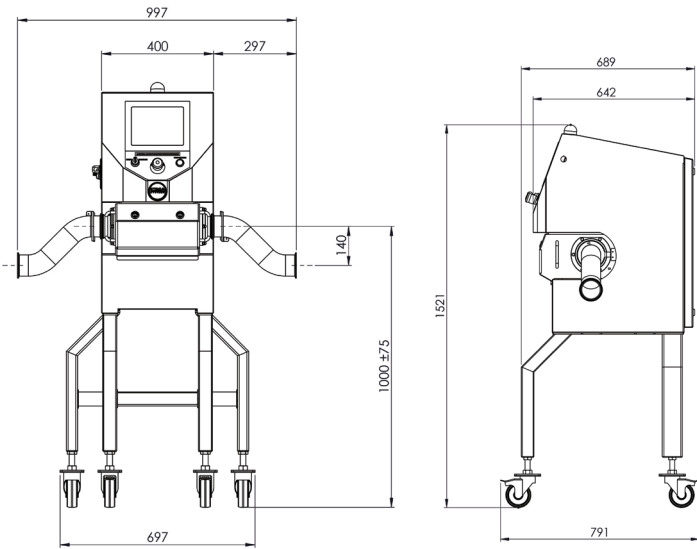

Finish	304 Stainless Steel (Brushed)
System Length	400mm (without Reject Valve or S-Bends)
Line Height Option	750 800 850 900 950 1000 ±50 mm adjustment
Pipe Diameter	2.5" (64 mm) 3" (75 mm)
Maximum Product Temperature	85 °C (185 °F)
Maximum Pipe Pressure	Signal Only: 20 Bar ARU Valve: 7 Bar ARL Valve: 10 Bar
X-Ray Output	100W (50kV 2 mA)
IP Rating	IP69k
Power Requirements	230V AC, 50Hz or 110v AC 60Hz, Single Phase Mains
Cooling	Vortex Cooler (requires compressed air connection)
Operating Environment	10 to 35 °C (50 - 95 °F)
	0 to 10 °C (32 - 50 °F) with cabinet warm-up enabled
X-Ray Safety	Leakage less than 1 µSv/h
Algorithms	2 x Image Processing 2 x Contaminant Detection No Product Integrity
Reporting	Event, Batch, Shift, PVS
Data Retrieval	Via USB, Ethernet

Automatic Reject Options

The X5 Pipeline can be used with the following reject options:

- Signal Only - A relay output is triggered on rejection and can be used to stop a pump
- ARU 2.5" Valve - Piston type device (includes Reject Confirmation Sensor), most common for meat filler/pump applications
- ARL 2.5" or 3" Valve - Arc design typically used for most applications and suitable for whole muscle meat. (no reject confirmation)

Please consult LOMA for a better understanding of which reject is suitable for which application.



An ITW Company

Loma Systems is a registered trademark of Illinois Tool Works Inc. (ITW). Other names, logos, icons and marks identifying our products and services referenced herein are trademarks of ITW and may not be used without the prior written permission of ITW. Other product and company names listed are trademarks or trade names of their respective companies. Copyright © 2018 Illinois Tool Works Inc. All rights reserved. All of the specifications shown in this document are subject to change without notice.

www.loma.com

Tel: +44(0)1252 893300 (UK) | +1-800-872-LOMA (North America)

Metal Detection | Checkweighing | X-Ray Inspection

In association with



XSPIPE_893201805